

# HITCH MOUNTED ALUMINUM CARRIER WITH RAMP FOR WHEELCHAIRS

---

ALMCARRIER

332203



## Operator's Manual

**TITAN**  
RAMPS



Read the Operator's Manual entirely. When you see this symbol, the subsequent instructions and warnings are serious follow without exception. Your life and the lives of others depend on it!

**PARTS DIAGRAM / EXPLODED VIEW**

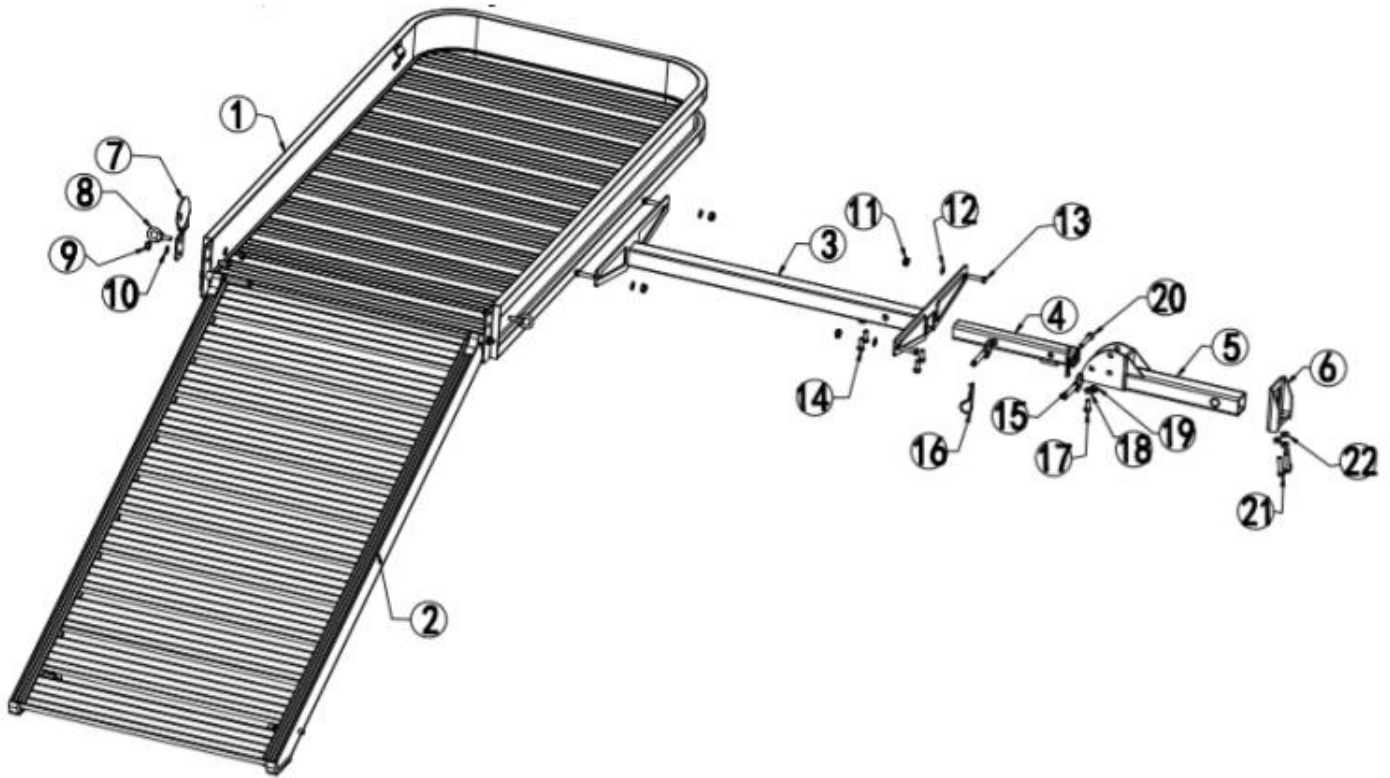

KEY	DESCRIPTION	QTY	KEY	DESCRIPTION	QTY
(1)	STORAGE BASKET ASSEMBLY	1	(12)	FLAT WASHER M10	4
(2)	AUXILIARY RAMP	1	(13)	EXTERNAL HEX SCREW M10*45	4
(3)	MAIN TUBE	1	(14)	EXTERNAL HEX SCREW M10*25	4
(4)	TUBE #4	1	(15)	ROUND CLIP WITH RING	2
(5)	TUBE #5	1	(16)	CLIP $\Phi$ 4	2
(6)	ANTI-DROP STOP	1	(17)	EXTERNAL HEX SCREW M12*25	1
(7)	FIXED PLATE	1	(18)	NUT M12	1
(8)	EYEBOLT M10*25 2	2	(19)	LOCK NUT M10	1
(9)	LOCK NUT M10	3	(20)	INTERNAL HEX SCREW M10*60	1
(10)	FLAT WASHER M10	3	(21)	EXTERNAL HEX SCREW M10*40	3
(11)	LOCK NUT M10 4	4	(22)	NUT M12	3

## **SAFETY INFORMATION**

---

### **SAFETY INFORMATION**

The maximum weight capacity for this product is 500 LB.  
Do not exceed the weight capacity.

## **ASSEMBLY INSTRUCTIONS**

---

- Assembly Instructions are not required.

## ACKNOWLEDGEMENT OF RISK AND RELEASE OF LIABILITY

---

The use of any equipment, including this one, involves the potential risk of injury. Apart from any warranty claim that might be presented for a claimed defect in material or workmanship of the product, you accept and assume full responsibility for any and all injuries, damages (both economic and non-economic), and losses of any type, which may occur, and you fully and forever release and discharge Titan, its insurers, employees, officers, directors, associates, and agents from any and all claims, demands, damages, rights of action, or causes of action, present or future, whether the same be known or unknown, anticipated, or unanticipated, resulting from or arising out of the use of said equipment.

This equipment must be used with care by capable and competent individuals under supervision, if necessary.

## TITAN LIMITED WARRANTY: TERMS, EXCLUSIONS AND LIMITATIONS OF REMEDIES

---

This product comes with a one (1) year limited warranty that can be found at [www.titanramps.com/warranty.html](http://www.titanramps.com/warranty.html). Please review the same for all details regarding the Titan Limited Warranty.

**THE TITAN LIMITED WARRANTY FOUND AT [WWW.TITANRAMPS.COM/WARRANTY.HTML](http://WWW.TITANRAMPS.COM/WARRANTY.HTML) IS EXCLUSIVE AND IS IN LIEU OF ALL OTHER WARRANTIES, EXPRESS OR IMPLIED, INCLUDING ANY IMPLIED WARRANTY OF MERCHANTABILITY AND/OR FITNESS FOR A PARTICULAR PURPOSE, EACH OF WHICH IS HEREBY DISCLAIMED.**



**NEED HELP? CONTACT US FIRST.**

**1-800-605-7555**

[info@titanramps.com](mailto:info@titanramps.com)

[www.titanramps.com](http://www.titanramps.com)

© 2021 Titan Brands